

CANOVA BED

ASSEMBLY INSTRUCTIONS

Parts And Fittings Packing Detail

BOX #1

- 1pc Head Board
- 1pc Foot Board

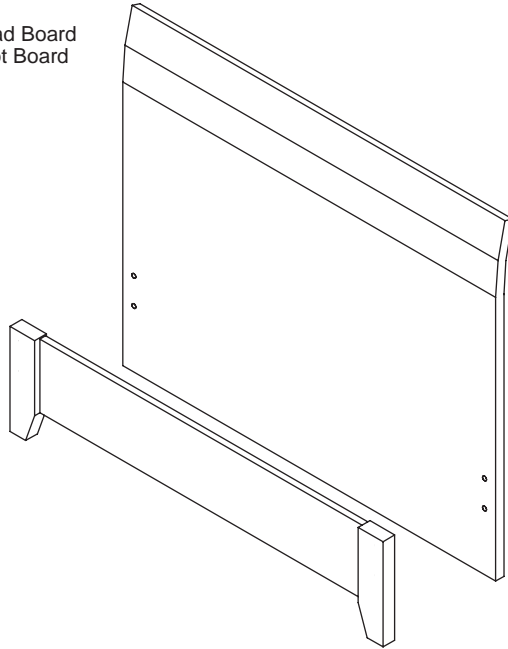

BOX #2

- 2pcs Side Rail
- 1pc Slat Support
- 4 pcs Support Leg

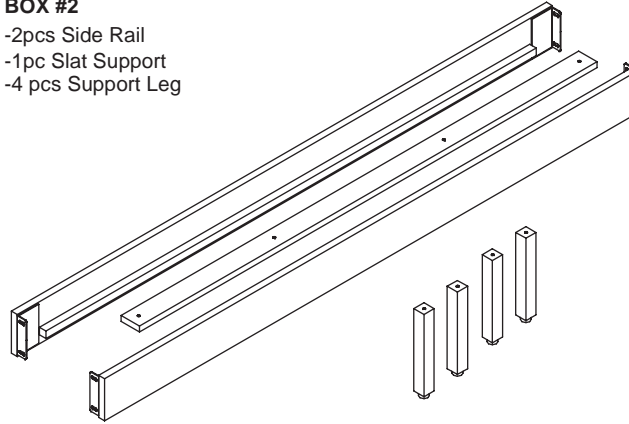

SLATS BOX

- 13pcs Slats

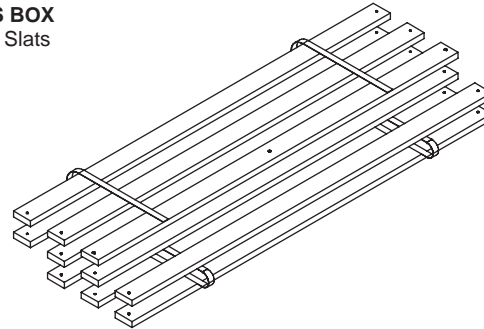

HARDWARE PACK IN BOX #1



Bolt
M8 x 45mm - 4 pcs



Bolt
M8 x 25mm - 4 pcs



Washer - 12 pcs.



Nuts - 4 pcs.



Bolts M6 x 70mm - 4 pcs.

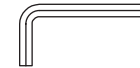

4mm Allen Key - 1 pc.

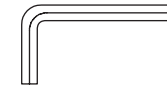

5mm Allen Key 1 pc.

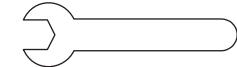

Wrench -1 pc.

Hardware Pack In Slats Box

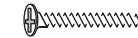

M4 x 32mm Screw - 26 pcs
(Wrapped in separate Plastic Bag)

*A complete assembled view of
a Conventional Bed*

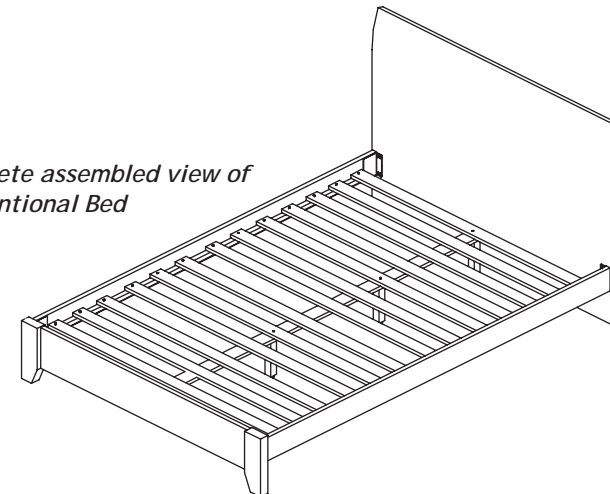

ASSEMBLY INSTRUCTIONS

STEP 1 / DIAGRAM 1

Fix both side rails to the Head Board and Foot Board as shown in diagram 1 with the 25mm and 45mm bolts and washers.

STEP 2 / DIAGRAM 2

Spread out all the slats on to the slat support. Further secure the pre-drilled slats to the slats support and support legs with 4nos M6 x 70mm bolt as shown in diagram 2.

STEP 3 / DIAGRAM 3

Finally, place both ends of the assembled slats in the bed frame resting on both sides of the side rails and screw them in place with the 32mm screws provided as shown in diagram 3

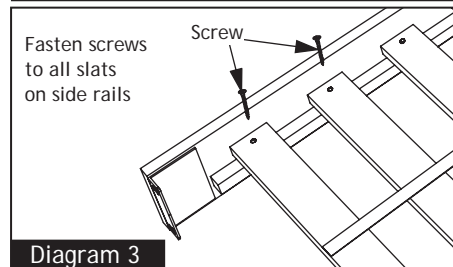
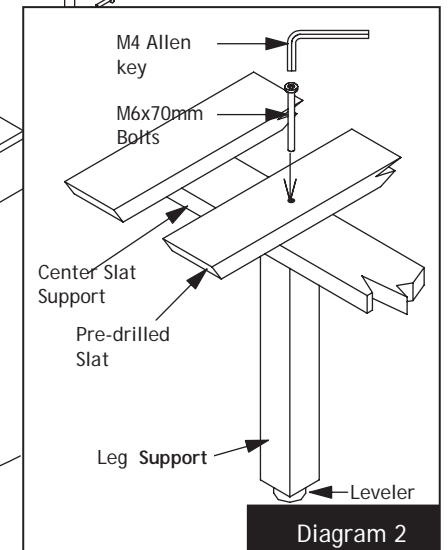
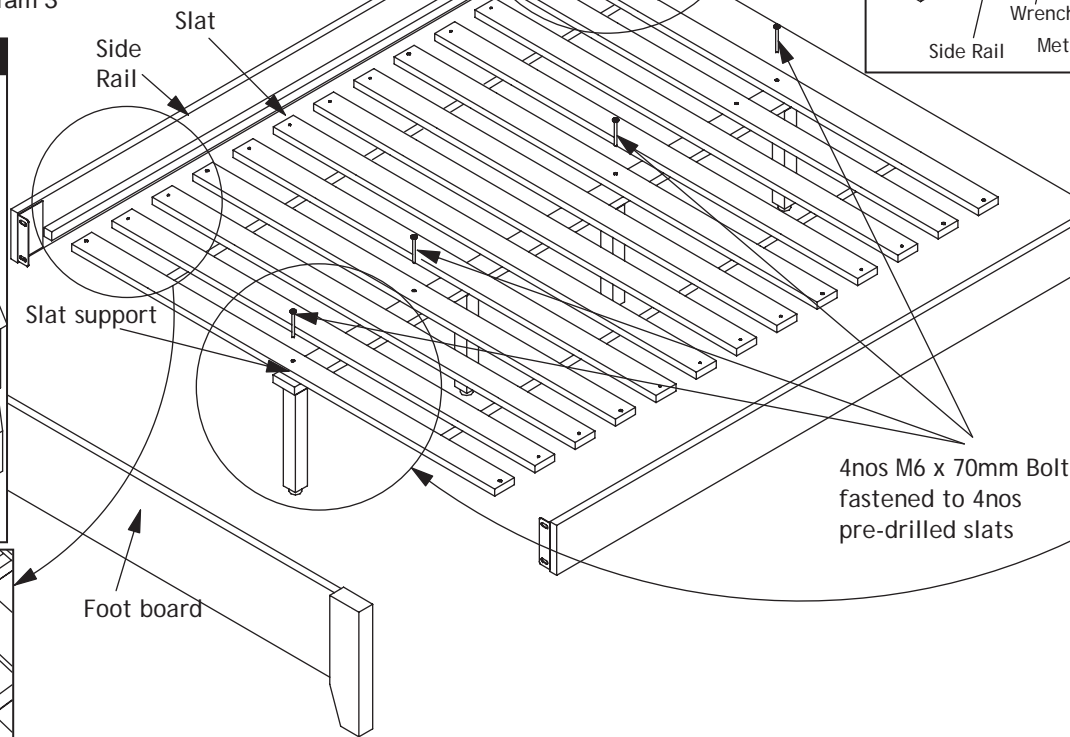
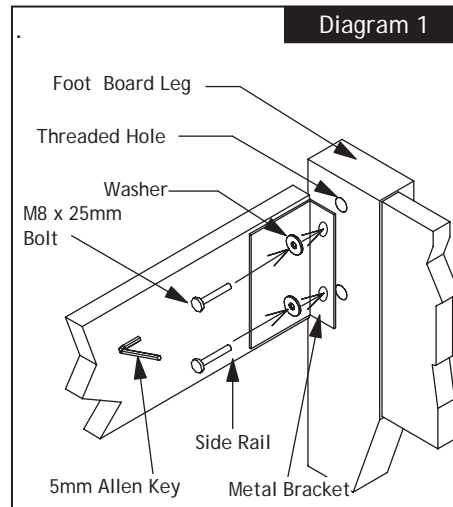
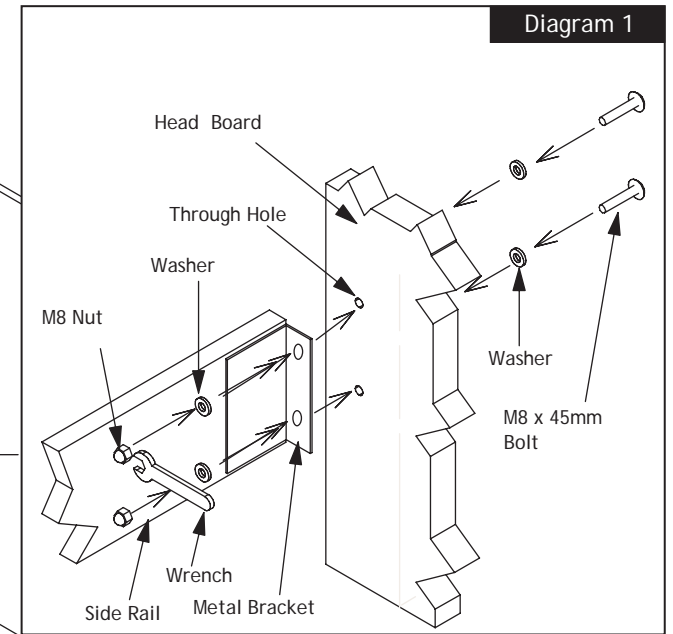

Diagram 1

Diagram 1

Diagram 2

Diagram 3