



LINON HOME DÉCOR PRODUCTS INC.

ASSEMBLY INSTRUCTIONS

LOW BACK HARDWOOD STORAGE BENCH WITH A SPLIT SEAT

84001 WAL-01-KD-U

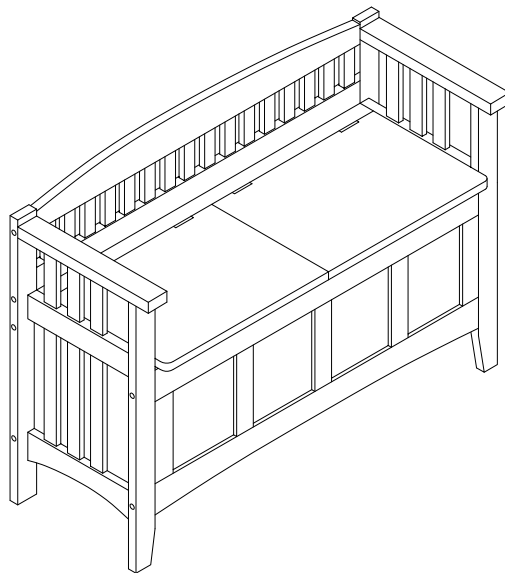

WE ARE HERE TO HELP !

WE DO OUR BEST TO INSURE THAT YOUR FURNITURE ARRIVES IN EXCELLENT CONDITION. IN THE EVENT THAT A PART IS DAMAGED OR MISSING, LINON HOME DECOR WILL BE HAPPY TO PROVIDE YOU WITH REPLACEMENT PARTS, AT NO CHARGE, WITHIN 30 DAYS OF PURCHASE, PROVIDING THE PARTS ARE AVAILABLE IN OUR WAREHOUSE AND THE ITEM PURCHASED ARE PART OF OUR CURRENT INVENTORY. IN ORDER TO RECEIVE SPARE PARTS, AT NO CHARGE, YOU MUST PROVIDE PROOF OF PURCHASE WITHIN 30 DAYS.

IF YOU NEED ASSISTANCE WITH ASSEMBLY OR REPLACEMENT PARTS, PLEASE CALL LINON CUSTOMER SERVICE, PRIOR TO RETURNING THE ITEM TO THE STORE.

OUR OFFICE IS OPEN MONDAY-FRIDAY 9AM-5PM, EASTERN STANDARD TIME.
OUR TOLL FREE CUSTOMER SERVICE NUMBER IS: 1-800-262-1852.
OR VISIT OUR WEB SITE WWW.LINON.COM TO ORDER SPARE PARTS AND FOR CARE INSTRUCTIONS ON YOUR NEWLY PURCHASED FURNITURE.

IMPORTANT:

PLEASE READ ALL INSTRUCTIONS IN THIS BOOKLET BEFORE STARTING ASSEMBLY.

MADE IN VIETNAM







FOR LINON HOME DECOR PRODUCTS INC BY V4

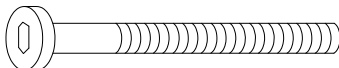

LINON HOME DÉCOR PRODUCTS INC.

HARDWARE PACKAGE COUNT

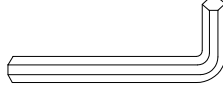
OPEN HARDWARE PACKAGE ON A FLAT SURFACE COVERED WITH NEWSPAPER. COUNT EACH PIECE OF HARDWARE TO MATCH THE QUANTITY NUMBER IN THE HARDWARE LIST COLUMN. CALL CUSTOMER SERVICE IF ANY OF THE PARTS ARE MISSING. FOLLOW THE LETTER IDENTIFICATION WHEN READING THE ASSEMBLY DRAWING "A" THROUGH "G"

| CODE | PICTURE | QTY |
|------|---|-----|
| A | 1/4"x3" BOLTS  | 12 |
| B | 3x15mm SCREWS  | 8 |
| C | LEFT SAFETY HINGE  | 1 |
| D | RIGHT SAFETY HINGE  | 1 |
| E | 1/4"x1-1/8" BOLTS (FOR SEAT)  | 3 |
| F | ALLEN KEY  | 1 |
| G | WOOD PLUGS  | 12 |

ALL PARTS ARE LABELED WITH STICKERS MATCHING THE PART IDENTIFICATION NUMBERS LISTED IN LEFT COLUMN.

IF ANY PARTS ARE MISSING OR DAMAGED IN THIS PACKAGE, LINON HOME DECOR WILL BE HAPPY TO PROVIDE YOU WITH REPLACEMENT PARTS, AT NO CHARGE, WITHIN 30 DAYS OF PURCHASE, PROVIDING THE PARTS ARE AVAILABLE IN OUR WAREHOUSE AND THE ITEM PURCHASED IS PART OF OUR CURRENT INVENTORY. IN ORDER TO RECEIVE SPARE PARTS, AT NO CHARGE, YOU MUST PROVIDE PROOF OF PURCHASE WITHIN 30 DAYS.

CALL US TOLL FREE AT 1-800-262-1852. OR VISIT OUR WEB SITE WWW.LINON.COM TO ORDER SPARE PARTS AND FOR CARE INSTRUCTIONS ON YOUR NEWLY PURCHASED FURNITURE.

IMPORTANT

PLEASE USE ALL HARDWARE MENTIONED ABOVE AS THEY WILL ASSURE THE ITEM'S STABILITY AND SAFETY. A SCREWDRIVER (NOT PROVIDED BY LINON) IS REQUIRED TO SUCCESSFULLY AND FULLY ASSEMBLE THE PIECE.



LINON HOME DÉCOR PRODUCTS INC.

PART IDENTIFICATION:

| PART | DESCRIPTION | QTY |
|------|--------------------|-----|
| #1 | SEAT | 1 |
| #2 | SLATTED BACK | 1 |
| #3 | FRAMED BACK PANEL | 1 |
| #4 | FRAMED FRONT PANEL | 1 |
| #5 | LEFT SIDE FRAME | 1 |
| #6 | RIGHT SIDE FRAME | 1 |
| #7 | BOTTOM SHELF | 1 |

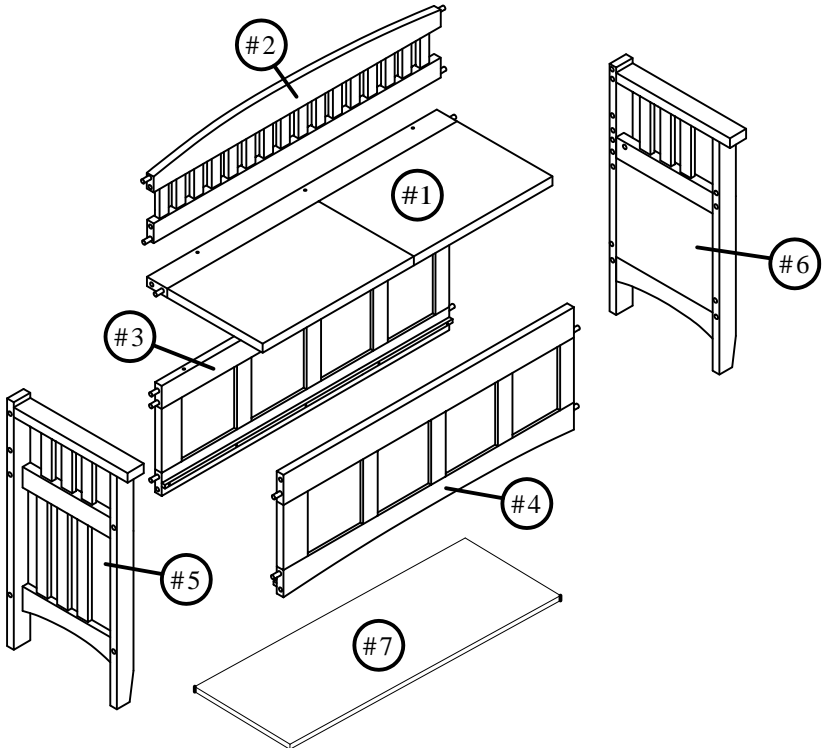



LINON HOME DÉCOR PRODUCTS INC.

STEP 1

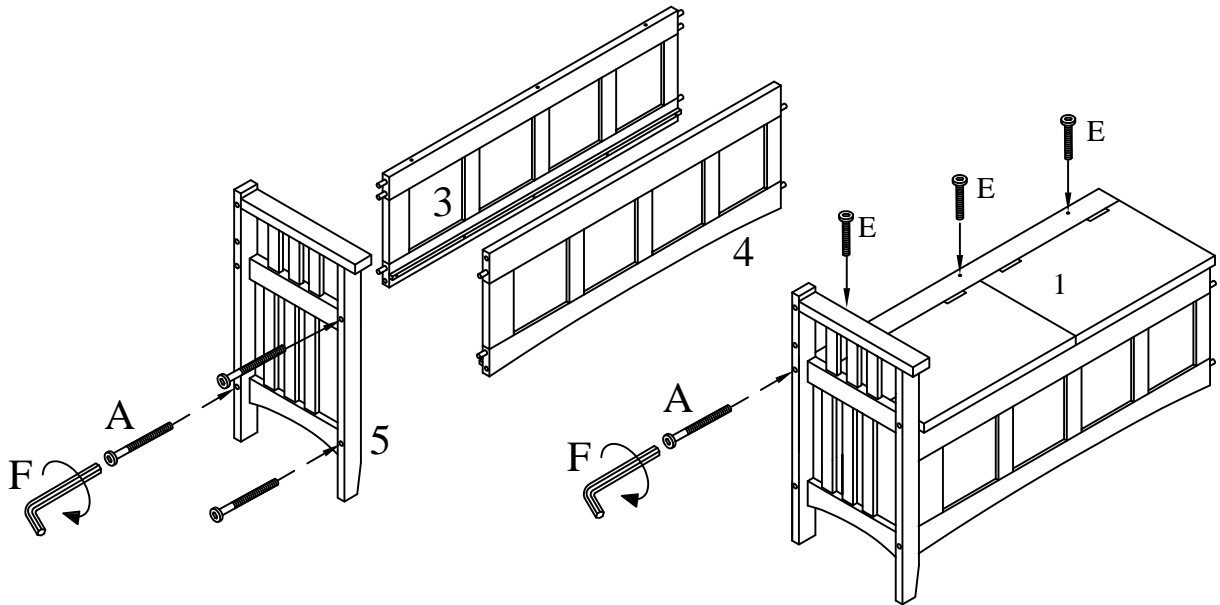

ATTACH FRAMED BACK PANEL (3) & FRAMED FRONT PANEL (4) TO LEFT SIDE (5). THEN SECURE WITH BOLTS (A) & ALLEN KEY (F). ATTACH SEAT (1) TO FRAMED BACK PANEL (3), AND SECURE IT WITH BOLTS (E) AND ALLEN KEY (F) AS SHOWN. THEN SECURE BOLT (A) TO ATTACH LEFT SIDE (5) TO SEAT (1) WITH ALLEN KEY (F).

STEP 2

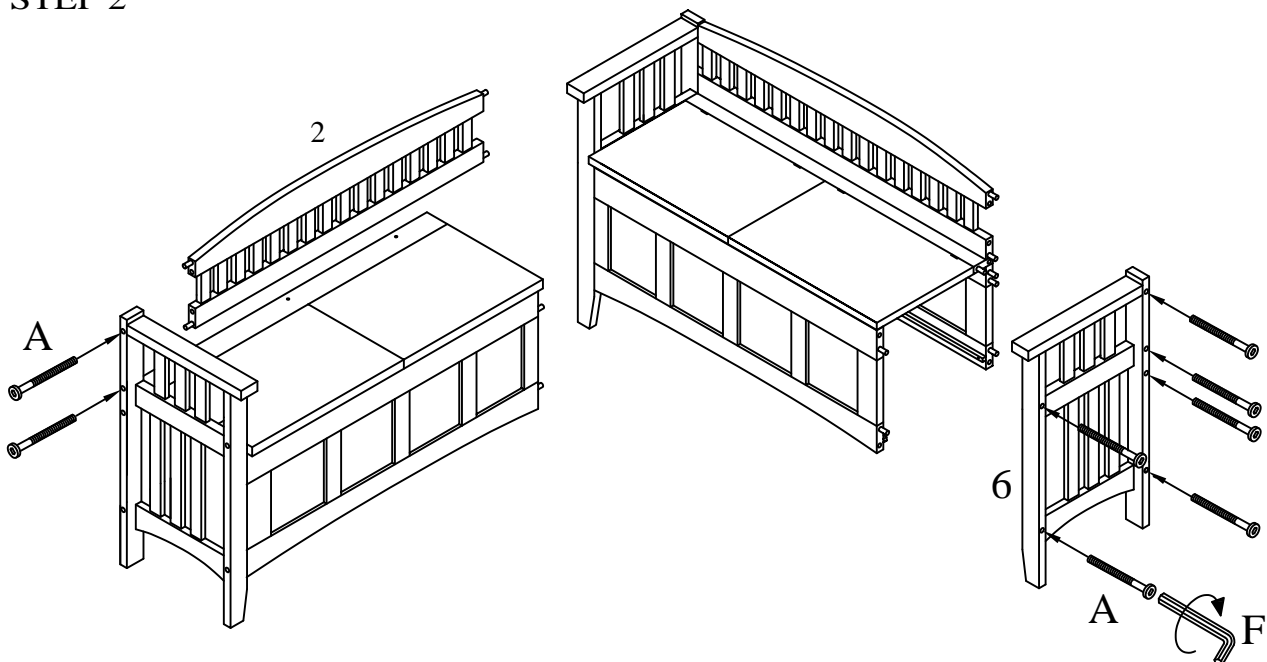

ATTACH SLATTED BACK (2) TO LEFT SIDE (5) AS SHOWN, AND SECURE WITH BOLTS (A) AND ALLEN KEY (F). ATTACH RIGHT SIDE (6) TO THE ASSEMBLED UNIT. THEN SECURE WITH BOLTS (A) & ALLEN KEY (F).



LINON HOME DÉCOR PRODUCTS INC.

STEP 3

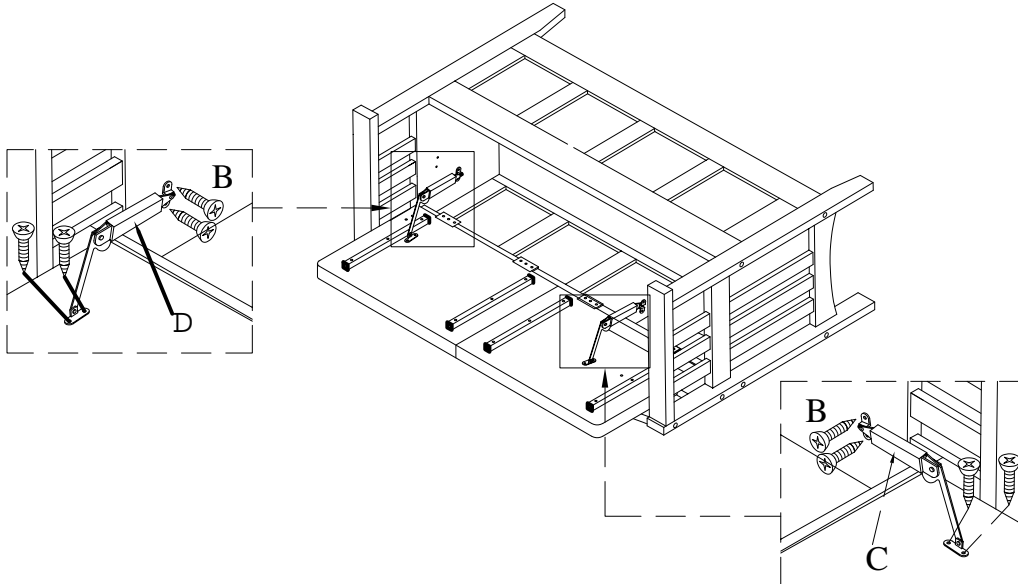

ATTACH LEFT SAFETY HINGE (C) TO THE LEFT SIDE FRAME (5) & THE BACK SIDE OF SEAT (1). THEN SECURE WITH SCREWS (B) BY SCREWDRIVER (NOT PROVIDED). SAME METHOD TO ASSEMBLE THE RIGHT SAFETY HINGE (D).

STEP 4

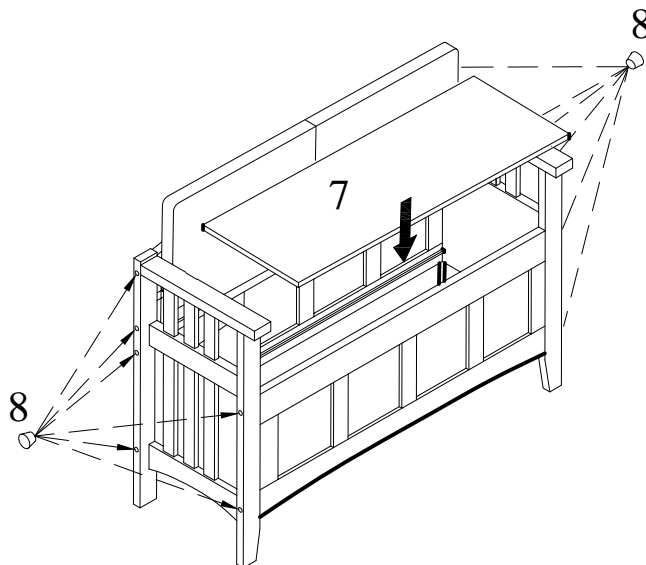

PLACE BOTTOM SHELF (7) ONTO THE WOOD PIECES ON FRAMED FRONT PANEL (4) AND FRAMED BACK PANEL (3). USE WOOD PLUGS (8) TO COVER THE HOLES ON THE SIDES.



LINON HOME DÉCOR PRODUCTS INC.

COMPLETED ASSEMBLY

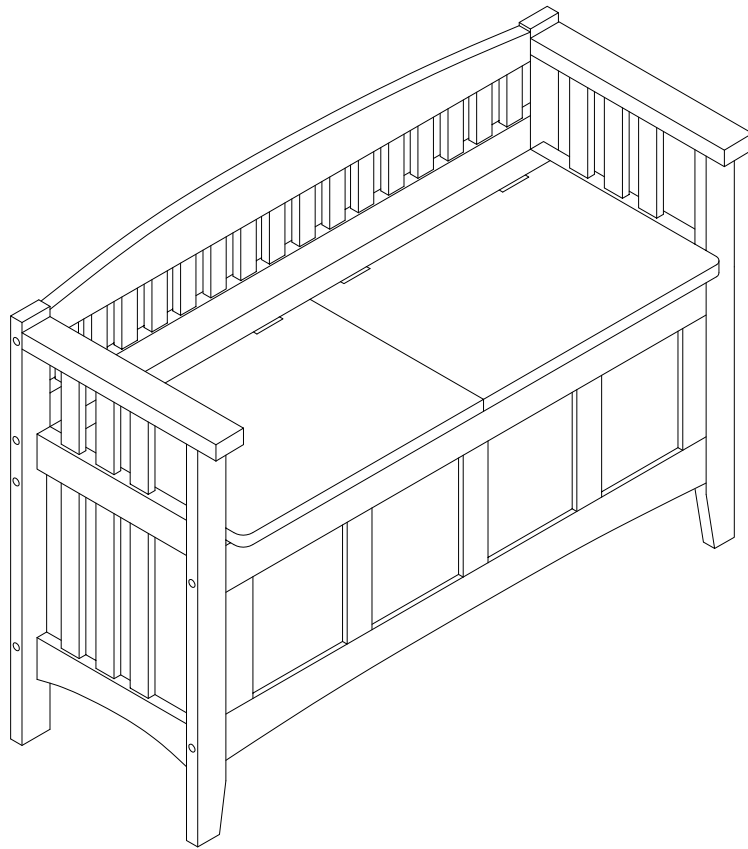



LINON HOME DÉCOR PRODUCTS INC.

LIMITED 6 MONTHS WARRANTY

WHAT IS COVERED

This product is covered under our manufacturer's 6 months limited warranty (Linon Home Décor Products). To ensure your complete satisfaction, this warrants to the original purchaser that the Linon supplied item is free from defects in material and workmanship, as of the date of purchase, and that it will, under normal use and proper care, remain so for six months after the date of purchase.

Replacement of missing or initially defective parts will be sent, at no charge, for a period of 30 days from the date of purchase with valid proof of purchase providing the parts are available in our warehouse and the item purchased is part of our current inventory.

WHAT IS NOT COVERED

It remains the customer's responsibility for freight and packaging charges to and from the customer service center. Labor and material charges to remove or replace parts under this warranty are not covered.

This warranty does not cover furniture used for commercial purposes, failures caused by improper care, unreasonable or abusive use, freeze damage, acts of God, rust, purchased parts or return freight and packaging charges. Proof of purchase (dated register receipt) is required for warranty claims.

HOW TO OBTAIN SERVICE

For further information, please contact our customer service department, c/o Linon Home Décor Products, Inc., between 9:00 AM and 5:00 PM Eastern Standard Time, Monday through Friday

LINON HOME DÉCOR PRODUCTS, INC.
CUSTOMER SERVICE DEPARTMENT
22 JERICHO TURNPIKE
MINEOLA, N.Y. 11501

Toll Free number : 1-800-262-1852 Customer Service
Visit our web site www.Linon.com to order spare parts and for care instructions on your newly purchased furniture.