

## Part List For Grenada Bed

### BED GRILL CARTON

(1) PANEL-2  
 PART #303801 HARDWARE BAG FOR BED ATTACHMENT TO FRAME

- (2) 1/4-20 3 1/2" FLAT ALLEN HEAD SCREW-8
- (3) 1/4-20 1" FLAT ALLEN HEAD SCREW-2
- (4) 1/4-20 FLANGE HEX NUT-8
- (5) 7/8" OD RUBBER WASHER-8
- (6) ALLEN WRENCH
- (7) FOOT CASTING -2 (PART# 30380494)
- (8) FINIAL -4 (PART# 30380394)

### BED POST CARTON

(9) HEADBOARD POST-2  
 (10) FOOTBOARD POST-2  
 PART #303805 HARDWARE BAG FOR BED POST MOUNTING  
 (11) 1 1/4" LONG SELF DRILLING SCREW FOR WOOD -8

### HEADBOARD GRILL CARTON

(1) PANEL-1  
 PART #303802 HARDWARE BAG FOR HEADBOARD ATTACHMENT TO FRAME

- (2) 1/4-20 3 1/2" FLAT ALLEN HEAD SCREW-4
- (4) 1/4-20 FLANGE HEX NUT-4
- (5) 7/8" OD RUBBER WASHER-4
- (6) ALLEN WRENCH
- (8) FINIAL -2 (PART# 30380394)

### BED POST CARTON

(9) HEADBOARD POST-2  
 PART #303806 HARDWARE BAG FOR HEADBOARD POST MOUNTING  
 (11) 1 1/4" LONG SELF DRILLING SCREW FOR WOOD -4

1 	2 	3 	4 
5 	6 	7 	8 
9 	10 	11 	

## PRODUCT FULLY ASSEMBLED

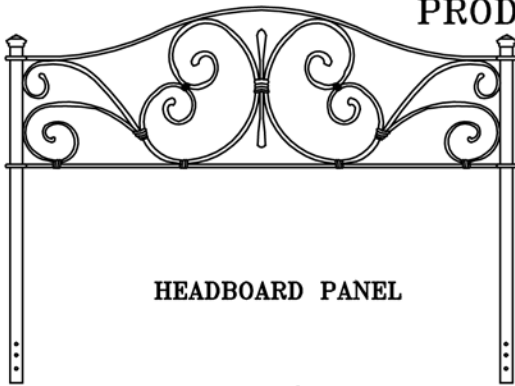

HEADBOARD PANEL



FOOTBOARD PANEL

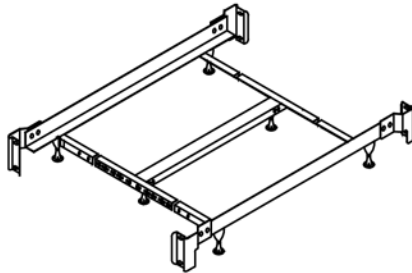

QUEEN - KING BED FRAME FULLY ASSEMBLED  
 NOTE: SEE INSTRUCTIONS INCLUDED IN FRAME CARTON FOR FRAME ASSEMBLY

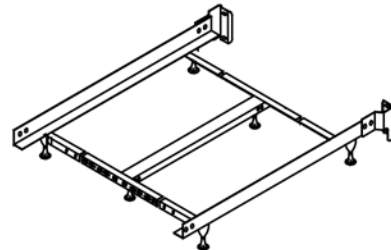

QUEEN - KING HEADBOARD ONLY FRAME FULLY ASSEMBLED FRAMES  
 NOTE: SEE INSTRUCTIONS INCLUDED IN FRAME CARTON FOR FRAME ASSEMBLY

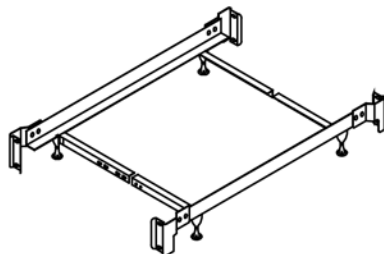

TWIN - FULL BED FRAME FULLY ASSEMBLED  
 NOTE: SEE INSTRUCTIONS INCLUDED IN FRAME CARTON FOR FRAME ASSEMBLY

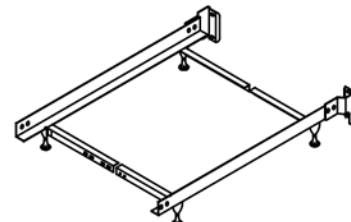

TWIN - FULL HEADBOARD ONLY FRAME FULLY ASSEMBLED  
 NOTE: SEE INSTRUCTIONS INCLUDED IN FRAME CARTON FOR FRAME ASSEMBLY

# Instruction Sheet

SAVE ALL PACKAGING MATERIALS UNTIL PRODUCT IS FULLY ASSEMBLED. HARDWARE AND SMALL PIECES MAY NOT BE SEEN AND BE ACCIDENTALLY DISCARDED WITH PACKAGING MATERIALS.

FIGURE 1

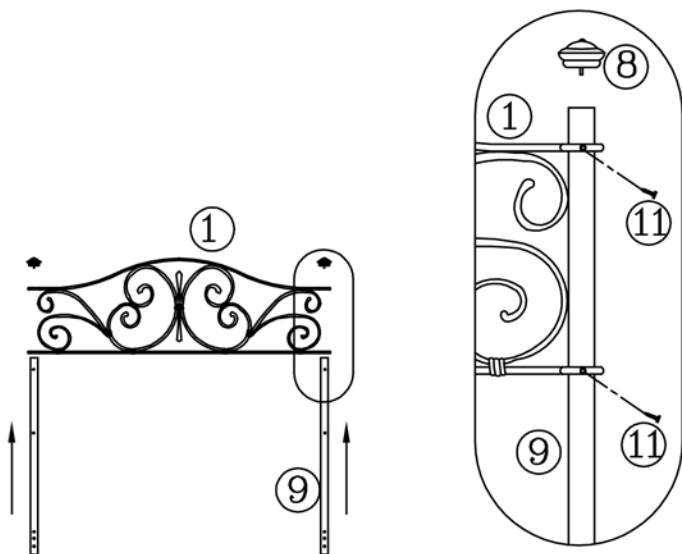

FIGURE 2

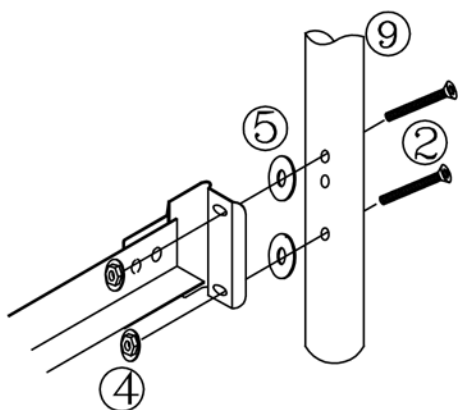
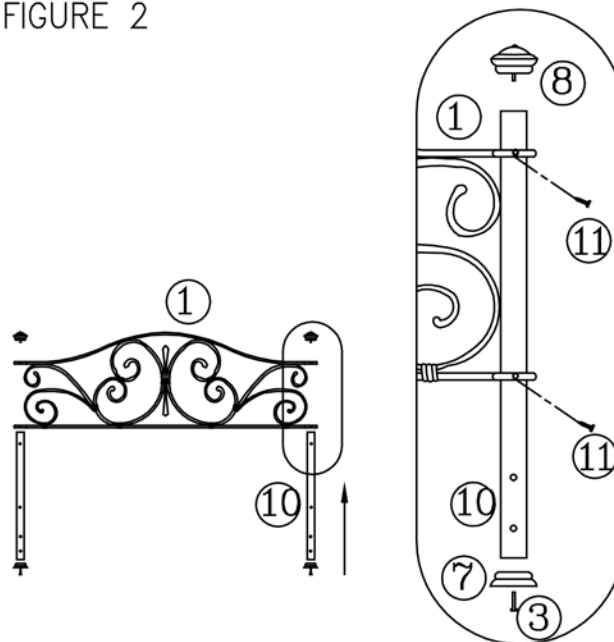

FIGURE 3

### Step 1

- Note: Use long posts for headboard assembly.
- Place grill (1) on a flat surface for easy assembly. Making sure welding joints are facing up.
- Insert post (9) thru rings on grill (1). Be sure to align pre-drill holes in post (9) with holes in rings.
- Now insert self drilling screw (11) thru ring into post (9).
- Do the same on other post. For assembly of footboard follow same instructions as for headboard. Make sure all wood screws are tighten. (See Fig.1 & 2)

### Step 2

- Secure foot casting (7) with screw (3) under post (10). (See Fig.2)
- Screw finial (8) on top of headboard and footboard posts. (See Fig.1 & 2)

### Step 3

- Place headboard and frame in desired location in room.
- Place 2 screws (2) through holes located in post (9). (See Figure 3) Slide rubber washer (5) over screw (2).
- Align bed frame bracket over screws.
- Place a nut (4) on each screw. Hand-tighten, DO NOT TIGHTEN screws all the way.
- Repeat on other side of headboard.
- Tighten all screws securely using the Allen wrench.

### Step 4

- Position footboard panel and align holes in the post with holes in the frame bracket. (See figure 4)
- Place 2 screws (2) through holes located in post (10). (See Figure 3) Slide rubber washer (5) over screw (2).
- Align bed frame bracket over screws.
- Place a then a nut (4) on each screw. Hand-tighten, DO NOT TIGHTEN screws all the way.
- Repeat on other side of footboard panel.
- Tighten all screws securely using the Allen wrench.

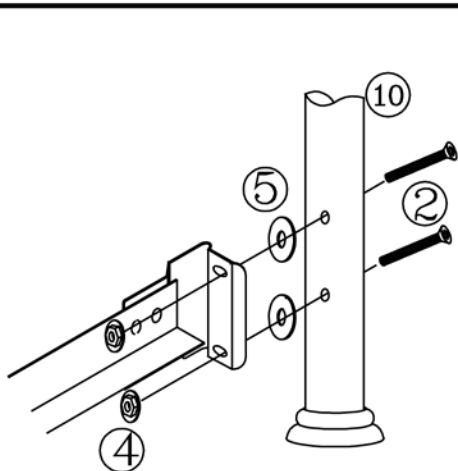

FIGURE 4