

# Fashion Bed Group

A Division of Leggett & Platt Incorporated

## Parts List For Riviera

### BED CARTONS

#### GRILL BOX

- (1) HEADBOARD GRILL (1)
- (2) FOOTBOARD GRILL (1)

PART #3069R01 HARDWARE BAG FOR BED FRAME ATTACHMENT

- (3) 1/4-20 4 5/8" FLAT ALLEN HEAD SCREW-4
- (4) 1/4-20 1 1/4" FLAT ALLEN HEAD SCREW-4
- (5) 1/4" ID METAL WASHER-8
- (6) 1/4-20 HEX NUT-4
- (7) ALLEN WRENCH-1
- (8) OPEN WRENCH-1
- (9) 1/4-20 2" THREADED ROD FULL-4
- (10) 7/8" RUBBER WASHER-8

#### POST BOX

- (11) HEADBOARD POST-2
- (12) FOOTBOARD POST-2
- (13) METAL FINIAL-4 (#3069R02119)
- (14) WOOD FINIAL-4 (#3069R03119) PRE-ASSEMBLED
- (15) FOOT-4 (#3069R04119) PRE-ASSEMBLED

PART #3069R04 HARDWARE BAG FOR BED GRILL ASSEMBLY

- (16) 1/4-20 1" FLAT ALLEN HEAD SCREW-8
- (7) ALLEN WRENCH-1

### HEADBOARD CARTONS

#### GRILL BOX

- (1) HEADBOARD GRILL (1)

PART #3069R02 HARDWARE BAG FOR HEADBOARD FRAME ATTACHMENT

- (3) 1/4-20 4 5/8" FLAT ALLEN HEAD SCREW-4
- (5) 1/4" ID METAL WASHER-4
- (6) 1/4-20 HEX NUT-4
- (7) ALLEN WRENCH-1
- (8) OPEN WRENCH-1
- (9) 1/4-20 2" THREADED ROD FULL-2
- (10) 7/8" RUBBER WASHER-4

#### POST BOX

- (11) HEADBOARD POST-2
- (13) METAL FINIAL-2 (#3069R02119)
- (14) WOOD FINIAL-2 (#3069R03119) PRE-ASSEMBLED
- (15) FOOT-2 (#3069R04119) PRE-ASSEMBLED

PART #3069R05 HARDWARE BAG FOR HEADBOARD GRILL ASSEMBLY

- (16) 1/4-20 1" FLAT ALLEN HEAD SCREW-4
- (7) ALLEN WRENCH-1

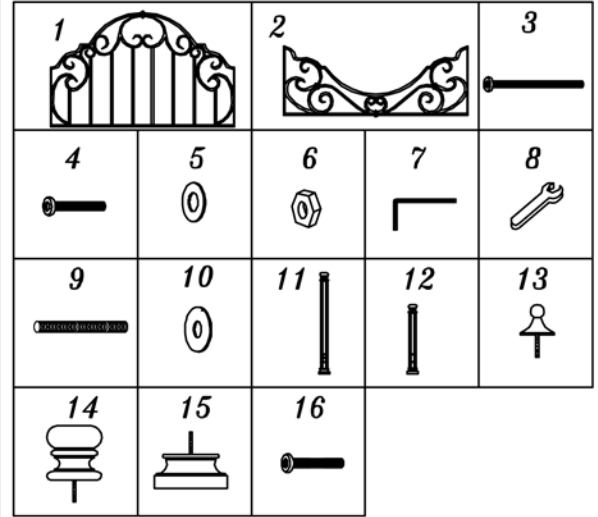

## PRODUCT FULLY ASSEMBLED

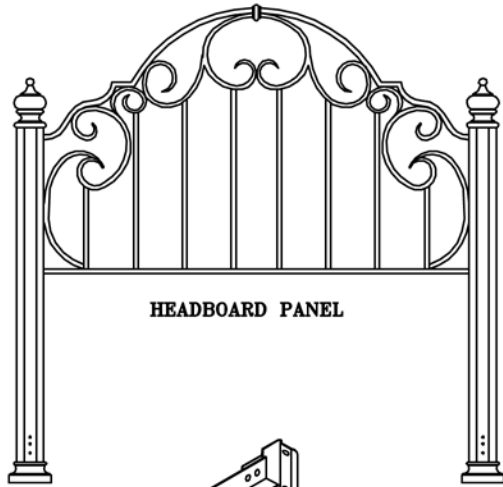

HEADBOARD PANEL

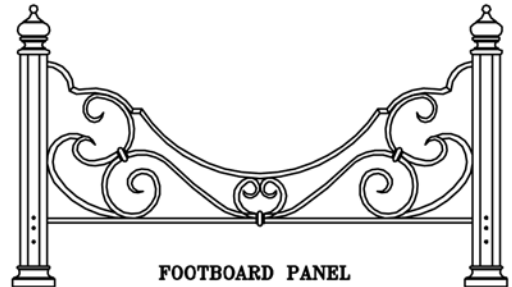

FOOTBOARD PANEL

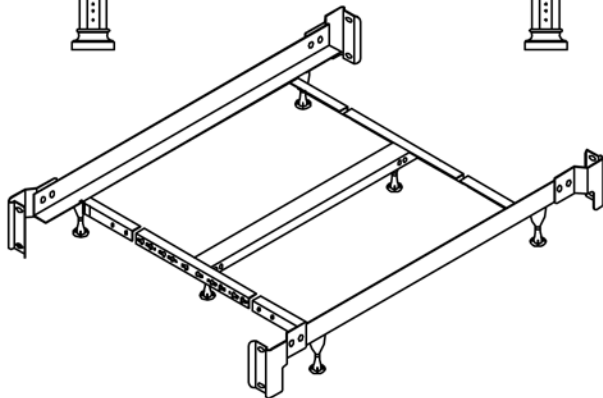

QUEEN - KING FRAME FULLY ASSEMBLED

NOTE: SEE INSTRUCTIONS INCLUDED IN FRAME CARTON FOR FRAME ASSEMBLY

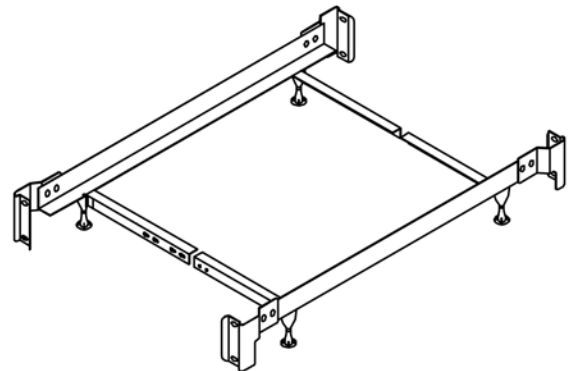

TWIN - FULL FRAME FULLY ASSEMBLED

NOTE: SEE INSTRUCTIONS INCLUDED IN FRAME CARTON FOR FRAME ASSEMBLY

# Instruction Sheet

SAVE ALL PACKAGING MATERIALS UNTIL PRODUCT IS FULLY ASSEMBLED. HARDWARE AND SMALL PIECES MAY NOT BE SEEN AND BE ACCIDENTALLY DISCARDED WITH PACKAGING MATERIALS.

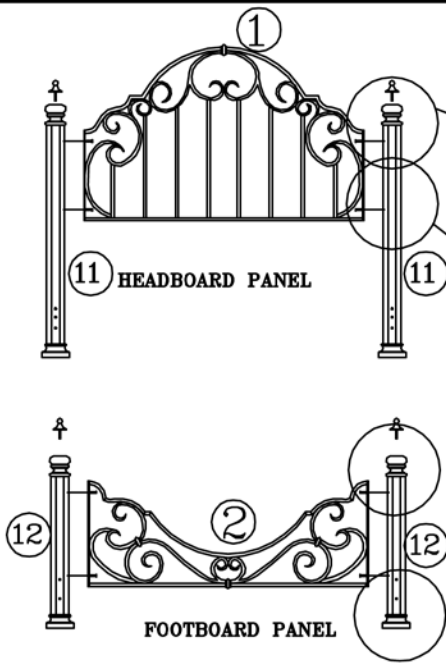

FIGURE 1

FIGURE 2

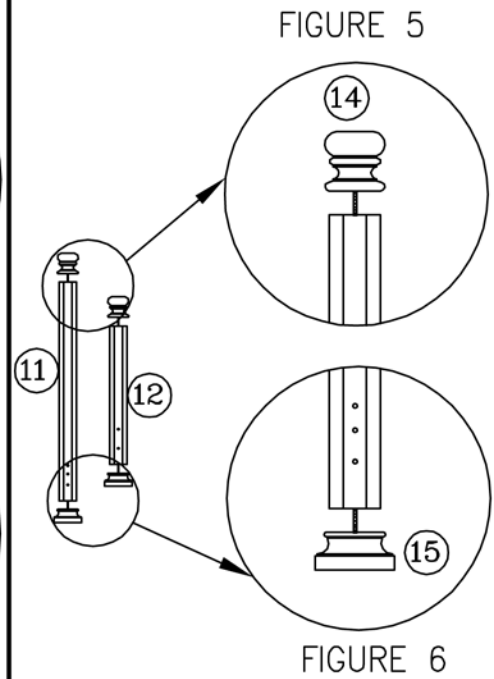

FIGURE 5

FIGURE 6

FIGURE 3

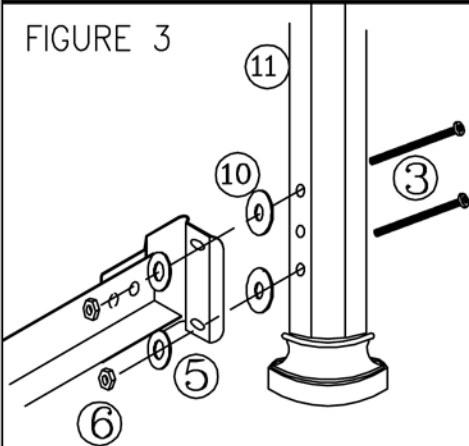
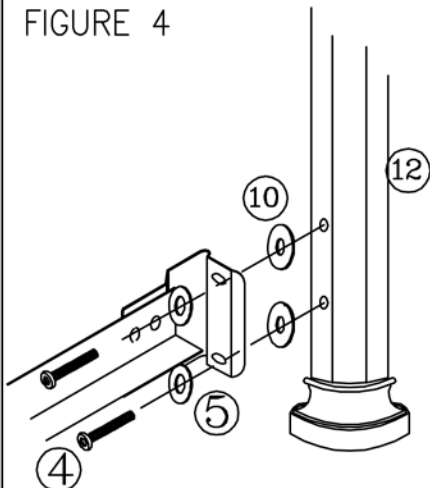

FIGURE 4



NOTE: Tighten wood finial (14) and foot (15) if loose. See Figures 5 & 6

## Step 1

- Screw rod (9) into the bottom of the finial (13). See Figures 1
- Now screw finial (13) with rod assembled into top of posts (11 & 12). See Fig. 1
- Align grill (1) end holes with holes in headboard post (11). See Figure 1
- Secure post (11) to grill (1) with screws (16). See Figure 1 & 2
- Repeat on other side of headboard panel and Footboard.
- Tighten all screws securely using the Allen wrench.

## Step 2

- Place headboard and frame in desired location in room.
- Place 2 screws (3) through holes located in post (11). (See Figure 3) Slide rubber washers (10) over screws (3).
- Align bed frame bracket over screws.
- Place a flat washer (5) first and then a nut (6) on each screw. Hand-tighten, DO NOT TIGHTEN screws all the way.
- Repeat on other side of headboard.
- Tighten all screws securely using the Allen wrench and open wrench.

## Step 3

- Position footboard panel and align holes in the post (12) with holes in the frame bracket. See figure 4
- Place flat washer (5) on each screw (4). Insert through bracket, rubber washer (10) and into post. Hand-tighten, DO NOT TIGHTEN screws all the way.
- Repeat on other side of footboard panel.
- Tighten all screws securely using the Allen wrench.