

# Fashion Bed Group

A Division of Leggett & Platt Incorporated

## Part List For Bianca Bed

### BED CARTONS

#### GRILLS BOX

(5) GRILL (2)

PART #363701 HARDWARE BAG FOR BED FRAME MOUNTING

- (1) 6MM X 3 1/2" FLAT ALLEN HEAD SCREW-8
- (2) 6MM HEX NUT-8
- (3) 5/8" OD FLAT METAL WASHER-16
- (4) ALLEN WRENCH

#### POST BOX

(6) HEADBOARD POST(2)

(7) FOOTBOARD POST(2)

(8) FINIALS -4 #363705

PART #363702 HARDWARE BAG FOR BED GRILLS ASSEMBLY TO POSTS

- (1) 6MM X 3 1/2" FLAT ALLEN HEAD SCREW-8
- (4) ALLEN WRENCH

### HEADBOARD CARTONS

#### GRILL BOX

(5) GRILL (1)

PART #363703 HARDWARE BAG FOR HEADBOARD FRAME MOUNTING

- (1) 6MM X 3 1/2" FLAT ALLEN HEAD SCREW-4
- (2) 6MM HEX NUT-4
- (3) 5/8" OD FLAT METAL WASHER-8
- (4) ALLEN WRENCH

#### POST BOX

(6) HEADBOARD POST(2)

(8) FINIALS -2 #363705

PART #363704 HARDWARE BAG FOR BED GRILL ASSEMBLY TO POSTS

- (1) 6MM X 3 1/2" FLAT ALLEN HEAD SCREW-4
- (4) ALLEN WRENCH

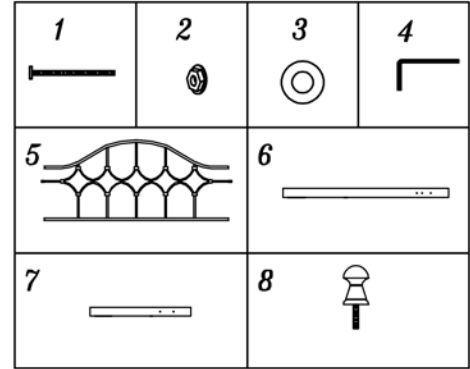

## PRODUCT FULLY ASSEMBLED

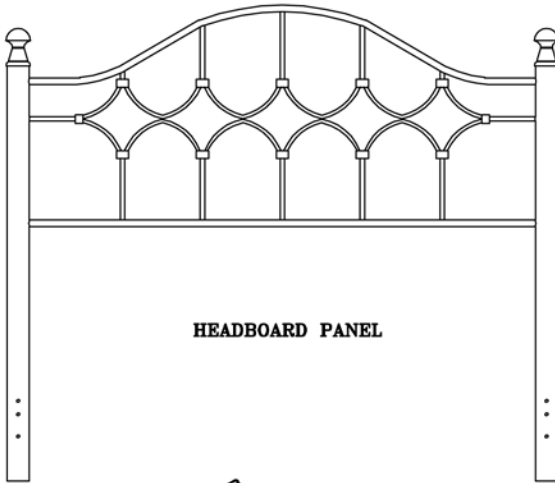

HEADBOARD PANEL

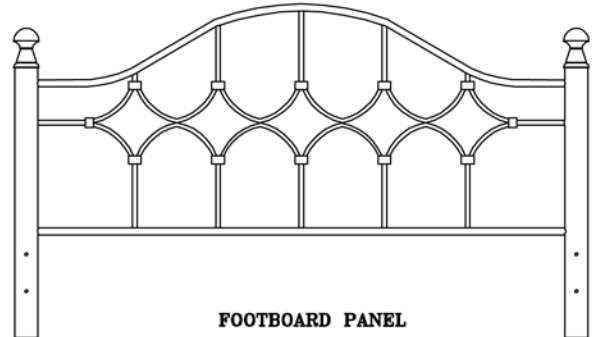

FOOTBOARD PANEL

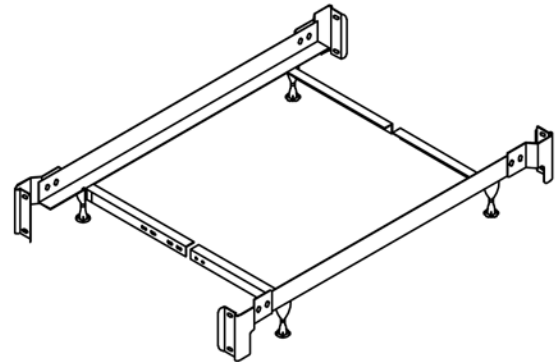
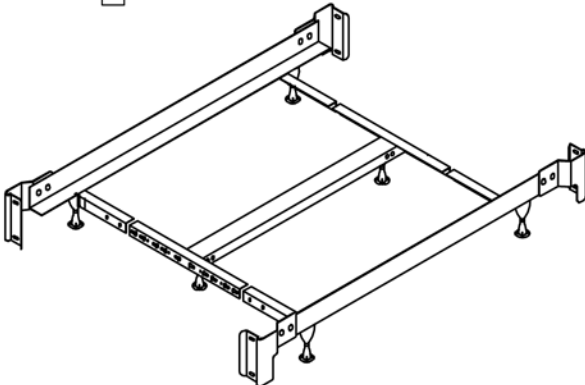

TWIN - FULL FRAME FULLY ASSEMBLED

NOTE: SEE INSTRUCTIONS INCLUDED IN FRAME CARTON FOR FRAME ASSEMBLY

QUEEN - KING FRAME FULLY ASSEMBLED

NOTE: SEE INSTRUCTIONS INCLUDED IN FRAME CARTON FOR FRAME ASSEMBLY

# Instruction Sheet

SAVE ALL PACKAGING MATERIALS UNTIL PRODUCT IS FULLY ASSEMBLED. HARDWARE AND SMALL PIECES MAY NOT BE SEEN AND BE ACCIDENTALLY DISCARDED WITH PACKAGING MATERIALS.

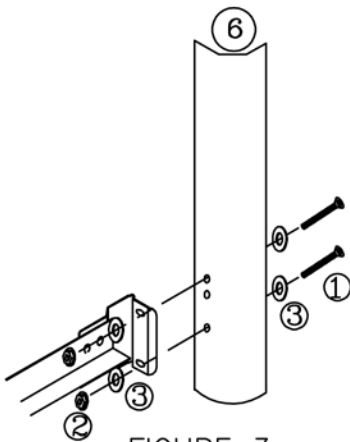
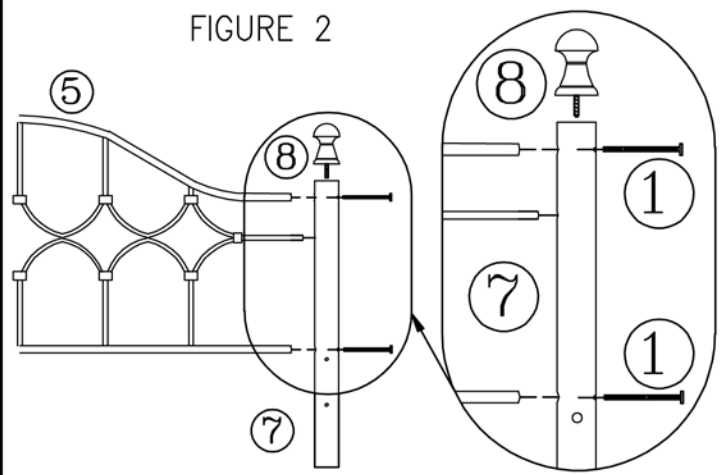
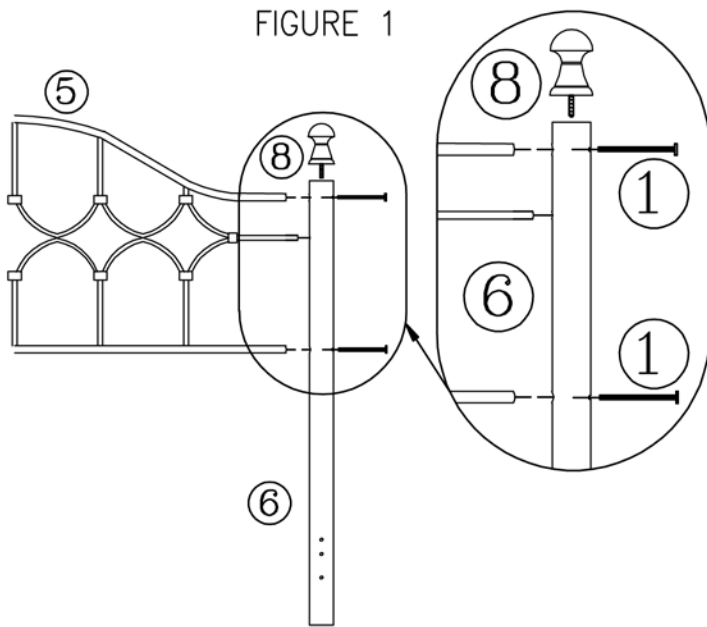

FIGURE 3

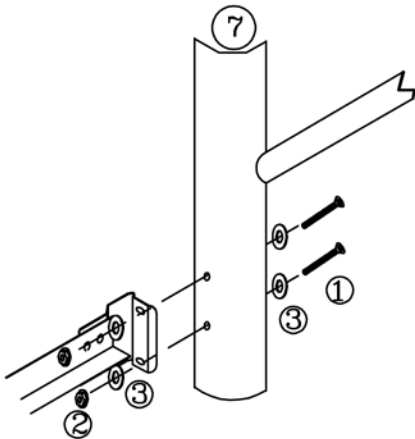

FIGURE 4

## Step 1

- Align grill (5) rails ends with holes in headboard post (6). (See Figure 1)
- Secure post (6) to grill (5) with screws (1). See Figure 1
- Repeat on other side of headboard panel.
- Tighten all screws securely using the Allen wrench (4).
- Repeat same step for assembly of footboard panel. (See Figure 2)
- Screw finial (8) on top of headboard post (6) and footboard Post (7). See figure 1-2

## Step 2

- Place headboard and frame in desired location in room.
- Place 2 washers (3) over screws (1) insert through holes located in post (6). (See Figure 3)
- Align bed frame bracket over screws.
- Place a washer (3) first and then a nut (2) on each screw. Hand, DO NOT TIGHTEN screws all the way.
- Repeat on other side of headboard.
- Tighten all screws securely using the Allen wrench (4).

## Step 3

- Position footboard panel and align holes in the post (7) with holes in the frame bracket. See Figure 4
- Place 2 washers (3) over screws (1) insert through holes located in post (7). (See Figure 4)
- Align bed frame bracket over screws.
- Place a washer (3) first and then a nut (2) on each screw. Hand, DO NOT TIGHTEN screws all the way.
- Repeat on other side of footboard.
- Tighten all screws securely using the Allen wrench (4).